

COOL-SPACE® 400

Complex facilities with changing layouts can be nearly impossible to cool. With an improved motor and updated blade design, Cool-Space® 400 delivers portable, powerful heat relief to facilities, warehouses, and outdoor spaces. Featuring a coverage area of 3,600 square feet and GREENGUARD Gold-certified cooling media, Cool-Space 400 brings rapid, reliable cooling comfort without compromise.



KEY FEATURES

- ▶ Quickly cool indoor and outdoor spaces by up to 33° F (18° C)
- ▶ Redesigned motor and aerodynamic fan blades deliver more efficient airflow
- ▶ Ideal for large factories, warehouses, and fitness centers
- ▶ Available push/pull bar kit for additional ergonomic portability
- ▶ 46-gallon (174-liter) reservoir lasts up to 10 hours without hose connection
- ▶ 36-inch (91-centimeter) fan diameter
- ▶ Optional All-Terrain version includes off-road tires and push/pull bar

COVERAGE AREA

UP TO 3,600 SQUARE FEET
(334 SQUARE METERS)

AIRFLOW

UP TO 6,700 CFM

CONTROL

VARIABLE SPEED
WITH PUMP ON/OFF SWITCH

VOLTAGE

120 VAC
OR
230 VAC



**COMFORT WITHOUT
COMPROMISE**

**DISCOVER MORE
ABOUT COOL-SPACE**

Learn more at bigassfans.com/evaporative-coolers/cool-space-400/ or call **877.BIG.FANS** for a free custom quote.

COOL-SPACE® 400

DELIVER COOLER CONDITIONS AT A MOMENT'S NOTICE

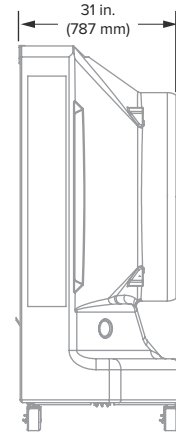
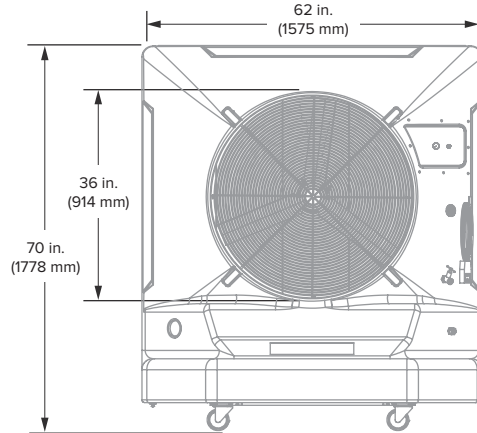

Technical Specifications

Model	Ordering Information	Input power and required breaker	Amperage ¹	Drive	Motor	Weight	Water Capacity	Inlet Water Supply Pressure	Environment ²	Airflow and Coverage	Sound Level ³	Operating Temperature
Cool-Space 400	E-400-3601 E-400-3602	120 VAC, 60 Hz, 1Φ, 15 A 220/230 VAC, 50/60 Hz, 1Φ, 10 A	8.75 A 5.52 A	Variable Speed	0.67 hp (0.5 kW)	220 lb (99.8 kg)	46 gal (174 L)	120 PSI Max	Well-ventilated indoor or outdoor space	Up to 6,700 cfm 3,600 sq ft	61 dBA	0 to 104 °F (-18 to 40 °C)

Construction

Housing	Motor	Power Supply	Water Supply	Cooling Media	Maintenance
UV-resistant roto-molded polyethylene housing Four swivel casters (two locking)	High-efficiency, totally enclosed	10 ft (3 m) power cord plugs into standard electrical outlet Cord wrap for easy storage	Accepts standard garden hose or portable supply tank Water level regulated by float valve Low-water shutoff for pump longevity	Made from thick cross-corrugated, angle-fluted formulated cellulose Treated with thermosetting resin for strength and prevention of algae	Accessible reservoir cap for convenient water treatment access Drain plug and flush valve for water removal



Onboard Variable Speed Control

¹ Maximum amperage includes both the fan and pump ratings.

² Not suitable for salt air environments.

³ Fans are sound tested in a laboratory environment. Actual results in field conditions may vary due to sound reflecting surfaces and environmental conditions.

Lead times may vary. See full warranty for coverage information.



USA
BIGASSFANS.COM
877-244-3267

CANADA
BIGASSFANS.COM
844-924-4277

AUSTRALIA
BIGASSFANS.COM/AU
1300 244 277

SINGAPORE
BIGASSFANS.COM/SG
65 6709 8500